

## Setup Guide Cutter Module (PA-CU-005) TJ-4420TN/4520TN/4620TN

### NOTE

- Only Authorized Brother Dealers or Certified Technicians should perform this optional installation.
- For more information about installation and use, contact your local Brother office.
- Disconnect the printer's AC Power Cord from the AC power outlet (electrical socket) before installing or removing the Cutter Module to avoid the risk of electrical shock.
- When installing the Cutter Module, do not twist, severely bend, pinch, or bind any cords. This may cause damage or malfunction.
- After installation or removal, DO NOT leave tools or hardware inside the label printer, otherwise an electrical shock may occur, or the machine may get damaged or destroyed by static electricity.
- DO NOT touch the printer parts with your bare hands as these parts may get damaged or destroyed by static electricity. Before touching the printer parts, place the printer on an Electrostatic Discharge (ESD) grounding mat or use anti-static gloves.
- Make sure not to lose the screws or other small parts during installation.
- DO NOT place the machine on an unstable surface, such as a table or shelf. If the machine falls, injuries may occur.

### NOTE

Place the printer close to the edge of a stable surface so that the Cutter Module can be fully opened during installation.

1. Open the Media Cover.
2. Remove the two Screws and pull out the Lower Front Panel.

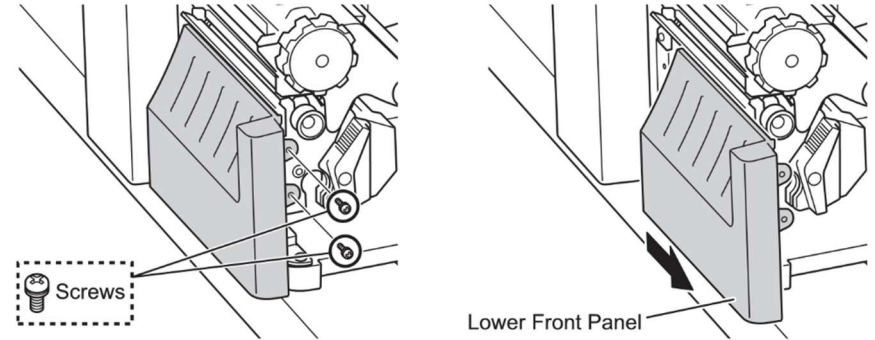

3. Remove the two Screws and then remove the Lower Bar.

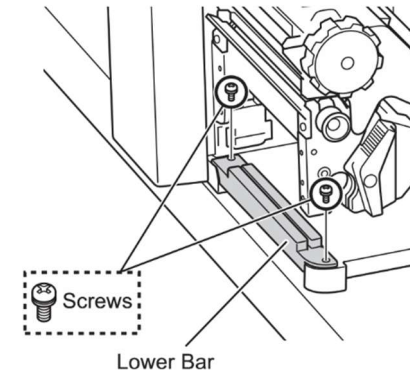

### Cutter Module

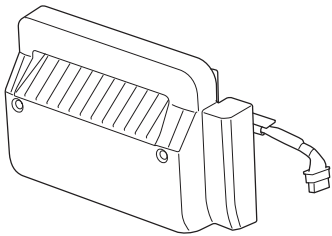

Shoulder Screw



Fixing Bolts

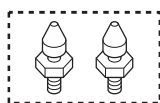

Screws

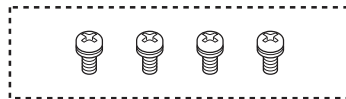

For the specific Label Printer part names, see section 2.2 *Printer Overview* in your label printer's *User's Guide*.

4. Make sure the AC Power Cord is disconnected from the AC power outlet (electrical socket), and then plug the Cutter Module Cable into the Cable Socket.

**NOTE**

- Secure the cable by affixing the Adhesive Hook onto the PCB side.
- **DO NOT** force the cable into the socket.
- Make sure you align the Cutter Module Cable's Connector with the Cable Socket before plugging the Cutter Module Cable, as illustrated.

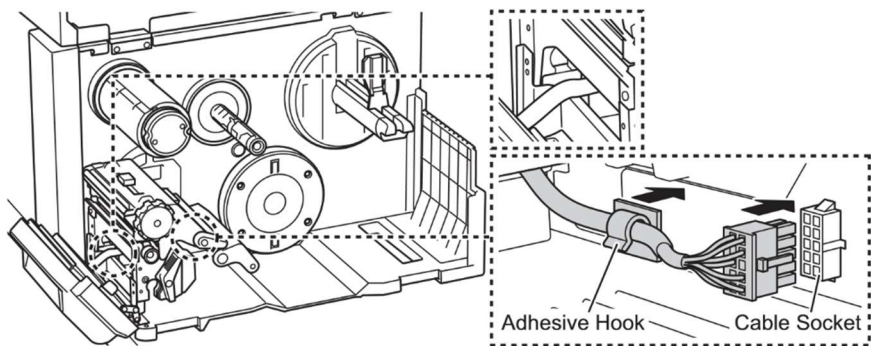

5. Mount the Cutter Module by inserting both bolts into the Mounting Holes, as illustrated.

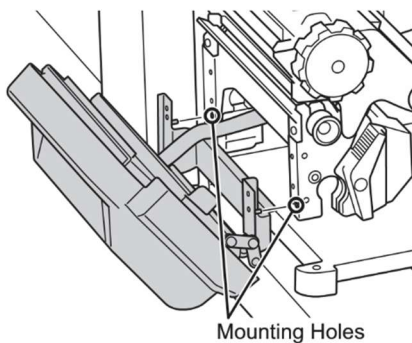

6. Fasten the two Fixing Bolts and four Screws to secure the Cutter Module (fastened by  $0.74 \text{ N} \cdot \text{m} \pm 0.10 \text{ N} \cdot \text{m}$ ).

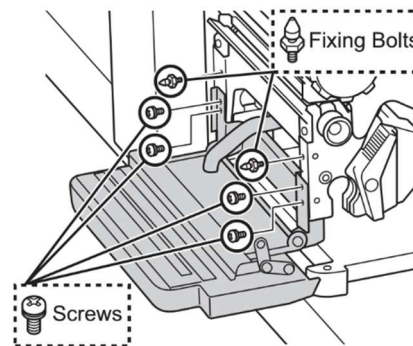

7. Fasten the Shoulder Screw on the Cutter Module plate as illustrated (fastened by  $0.74 \text{ N} \cdot \text{m} \pm 0.10 \text{ N} \cdot \text{m}$ ).

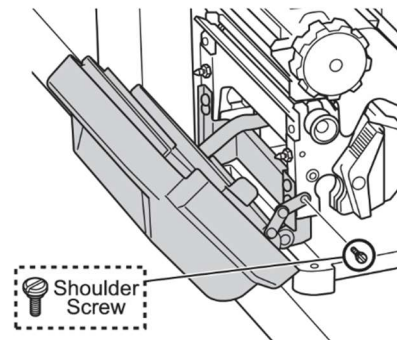

8. Complete the installation by loading the print media.

For more information about loading the media after installing the Cutter Module, see sections 3.2 *Load the Ribbon* and 3.4.4 *Load Media in Cutter Mode (Optional)* in your label printer's *User's Guide*.